

# The solution:

## Gas Distribution Network Robust and Safe.

- ✓ Residential Distribution Network is fully monitored
  - Sensors
  - Pipelines
  - Gas Tank
- ✓ Alarms on any abnormal situation: (Faulty valve or pressure relief, leakages...)
- ✓ Gas Network Control System.
- ✓ Preservation of historical events and faults.



# On Edge Solution - Retrofit Kit RF sensor transmitter

## Wireless Gas Meter

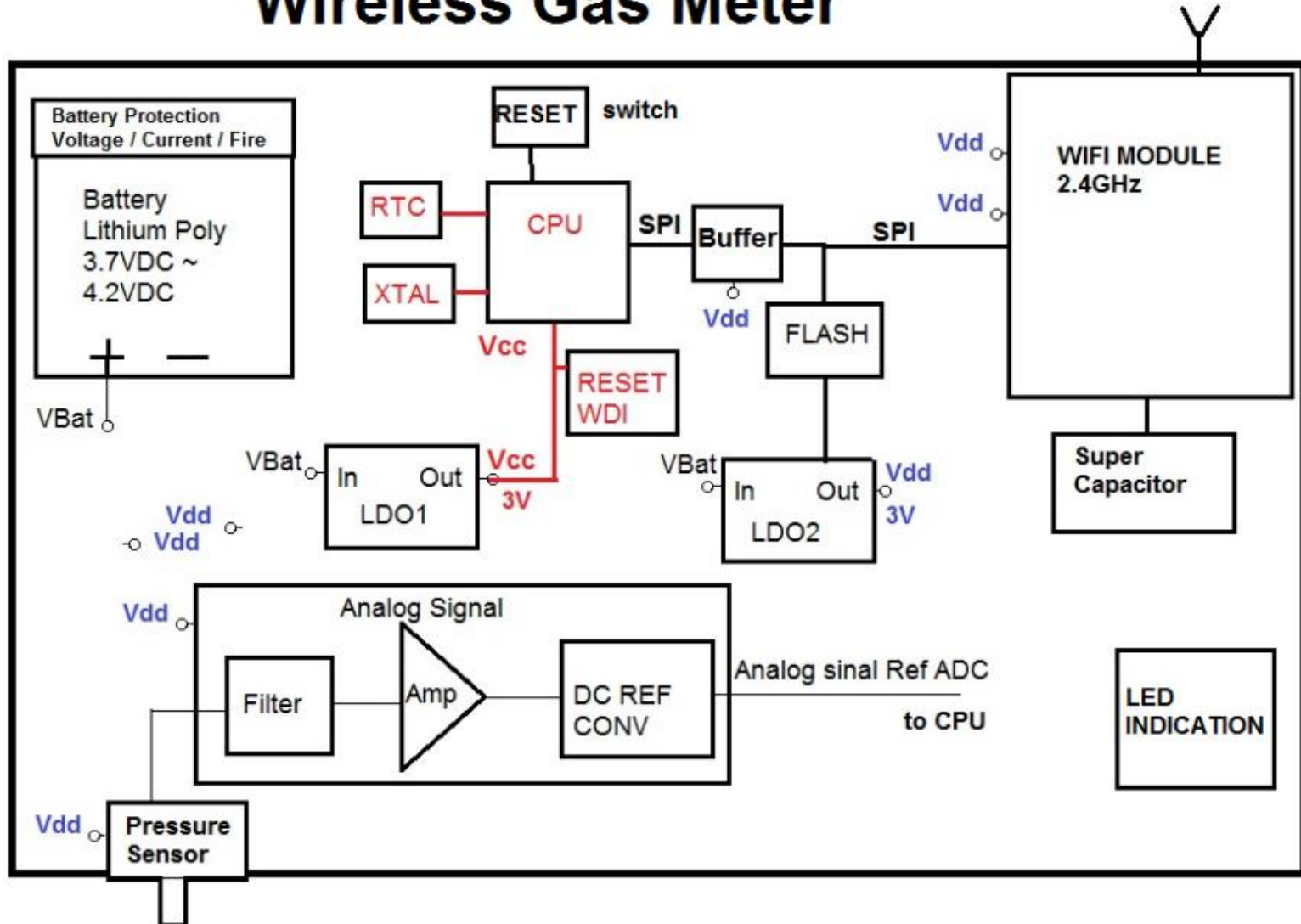

# Benefits

- ✓ Dramatically Reducing Maintenance cost
- ✓ Insurance premium cost **reduction**
- ✓ Minimal mean time to repair
- ✓ The safety gas distribution network – real time Leak detection system and stability assurance

## The Innovation

- ✓ Edge Computing is a new technique for making IoT base predictive maintenance more efficient and effective. You make your network resource much more efficient.
- ✓ You analyze the data online and your sample rate is much higher, hence your results are much more accurate and the response to the event is much faster.